

Isola AS, Platon Factory

Lienfossveien 5
N-3678 Notodden
Norway

Tel: 0047 3557 5700 Fax: 0047 3502 7555
e-mail: isola@isola.no
website: www.isola.com

Agrément Certificate
01/3823
Product Sheet 4

SYSTEM PLATON

PLATON P8

This Agrément Certificate Product Sheet⁽¹⁾ relates to Platon P8, a translucent high-density polyethylene (HDPE) membrane for damp-proofing walls, floors and ceilings in new construction or in existing buildings. It can be used above or below ground, over a contaminated or damp background, to support a dry lining or flooring.

(1) Hereinafter referred to as 'Certificate'.

CERTIFICATION INCLUDES:

- factors relating to compliance with Building Regulations where applicable
- factors relating to additional non-regulatory information where applicable
- independently verified technical specification
- assessment criteria and technical investigations
- design considerations
- installation guidance
- regular surveillance of production
- formal three-yearly review.



KEY FACTORS ASSESSED

Resistance to water and water vapour — the membrane is water resistant and has a high resistance to water vapour transmission (see section 6).

Resistance to salt transfer — the membrane provides an effective barrier to the transmission of salts or other contaminants from the substrate (see section 8).

Resistance to puncture, impact and loading — the membrane has a high resistance to puncture and will not be damaged by normal foot traffic during installation, or while laying concrete or screeding. It can support the long-term loadings likely to be experienced in service without undue deformation (see section 9).

Durability — under normal conditions of use the membrane will provide an effective barrier to the transmission of salts, liquid water and water vapour for the life of the structure in which it is incorporated (see section 12).

The BBA has awarded this Certificate to the company named above for the product described herein. This product been assessed by the BBA as being fit for its intended use provided it is installed, used and maintained as set out in this Certificate.

On behalf of the British Board of Agrément

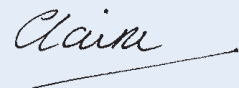
Date of Third issue: 17 February 2017

John Albon — Head of Approvals

Claire Curtis-Thomas

Originally certificated on 9 October 2001

Construction Products

Chief Executive

The BBA is a UKAS accredited certification body — Number 113. The schedule of the current scope of accreditation for product certification is available in pdf format via the UKAS link on the BBA website at www.bbacerts.co.uk

Readers are advised to check the validity and latest issue number of this Agrément Certificate by either referring to the BBA website or contacting the BBA direct.

British Board of Agrément

Bucknalls Lane
Watford
Herts WD25 9BA

tel: 01923 665300
fax: 01923 665301
clientservices@bba.star.co.uk
www.bbacerts.co.uk

©2017

Regulations

In the opinion of the BBA, Platon P8, if installed, used and maintained in accordance with this Certificate, can satisfy or contribute to satisfying the relevant requirements of the following Building Regulations (the presence of a UK map indicates that the subject is related to the Building Regulations in the region or regions of the UK depicted):



The Building Regulations 2010 (England and Wales) (as amended)

Requirement:	C2(a)(b)	Resistance to moisture
Comment:		The product adequately resists the passage of moisture. See section 6.1 of this Certificate.
Regulation:	7	Materials and workmanship
Comment:		The product is acceptable. See section 12 and the <i>Installation</i> part of this Certificate.



The Building (Scotland) Regulations 2004 (as amended)

Regulation:	8(1)	Durability, workmanship and fitness of materials
Comment:		The product is acceptable. See section 12 and the <i>Installation</i> part of this Certificate.
Regulation:	9	Building standards applicable to construction
Standard:	3.3	Flooding and ground water
Comment:		The product can contribute to minimising or eliminating the effects of flooding on the building fabric and/or the building element, with reference to clause 3.3.1 ⁽¹⁾⁽²⁾ . See section 6.1 of this Certificate.
Standard:	3.4	Moisture from the ground
Comment:		The product adequately resists the passage of moisture with reference to clauses 3.4.1 ⁽¹⁾⁽²⁾ , 3.4.2 ⁽¹⁾⁽²⁾ , 3.4.5 ⁽¹⁾⁽²⁾ , 3.4.6 ⁽¹⁾⁽²⁾ and 3.4.7 ⁽¹⁾⁽²⁾ . See section 6.1 of this Certificate.
Standard:	3.6	Surface water drainage
Comment:		The product can contribute to satisfying this Standard, with reference to clause 3.6.3 ⁽¹⁾⁽²⁾ . See section 6.1 of this Certificate.
Standard:	3.10	Precipitation
Comment:		The product adequately resists the passage of moisture, with reference to clause 3.10.1 ⁽¹⁾⁽²⁾ . See section 6.1 of this Certificate.
Standard:	7.1(a)	Statement of sustainability
Comment:		The product can contribute to meeting the relevant requirements of Regulation 9, Standards 1 to 6 and therefore will contribute to a construction meeting a bronze level of sustainability as defined in this Standard.
Regulation:	12	Building standards applicable to conversions
Comment:		All comments given for the product under Regulation 9, Standards 1 to 6 also apply to this Regulation, with reference to clause 0.12.1 ⁽¹⁾⁽²⁾ and Schedule 6 ⁽¹⁾⁽²⁾ . (1) Technical Handbook (Domestic). (2) Technical Handbook (Non-Domestic).



The Building Regulations (Northern Ireland) 2012 (as amended)

Regulation:	23(a)(i)(iii)(b)(i)	Fitness of materials and workmanship
Comment:		The product is acceptable. See section 12 and the <i>Installation</i> part of this Certificate.
Regulation:	28(a)(b)	Resistance to moisture and weather
Comment:		The product adequately resists the passage of moisture. See section 6.1 of this Certificate.

Construction (Design and Management) Regulations 2015

Construction (Design and Management) Regulations (Northern Ireland) 2016

Information in this Certificate may assist the client, designer (including Principal Designer) and contractor (including Principal Contractor) to address their obligations under these Regulations.

See section: 1 *Delivery and site handling* (1.2) of this Certificate.

Additional Information

NHBC Standards 2017

NHBC accepts the use of Platon P8, provided it is installed, used and maintained in accordance with this Certificate, in relation to *NHBC Standards*, Chapters 5.1 *Substructure and ground bearing floors* 5.2 *Suspended ground floors* and 5.4 *Waterproofing of basements and other below ground structures*.

Where Grade 3 waterproofing protection is required and the below-ground wall retains more than 600 mm (measured from the top of the retained ground to the lowest finished floor level), the product should be used in combination with either a Type A or Type B waterproofing protection.

NHBC accepts the use of the product on existing structures when installed and used in accordance with this Certificate and *NHBC Standards for Conversions and Renovations*, taking account of other relevant guidance within the chapter and the suitability of the substrate to receive the product.

CE marking

The Certificate holder has taken the responsibility of CE marking the product, in accordance with harmonised European Standard BS EN 13967 : 2012 and BS EN 13984 : 2013. An asterisk (*) appearing in this Certificate indicates that data shown are given in the manufacturer's Declaration of Performance.

Technical Specification

1 Description

1.1 Platon P8 is a translucent high-density polyethylene (HDPE) membrane, moulded to form raised studs at 25 mm centres (see Figure 1).

Figure 1 Platon P8

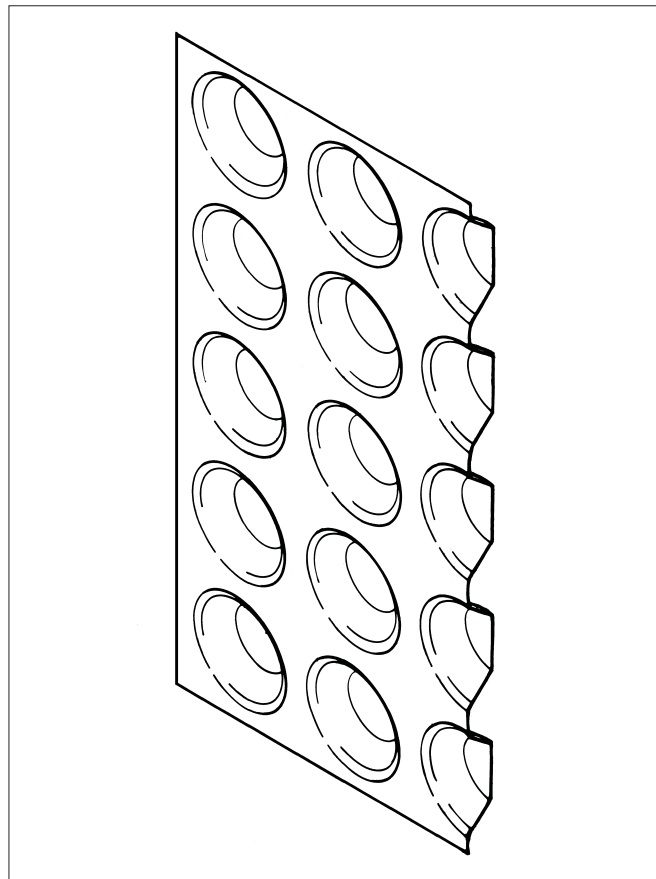

1.2 Platon P8 is supplied in roll form, and has the following nominal characteristics:

Thickness (mm)	0.5 approx
Stud height (mm)	6.5 approx
Weight per unit area ($\text{kg}\cdot\text{m}^{-2}$)	0.48
Roll size (m) ⁽¹⁾	2.07 x 20 and 2.47 x 20
Weight of roll (kg)	19.87 approx
Air gap volume ($\text{l}\cdot\text{m}^{-2}$)	3.2.

(1) Includes a 70 mm stud-free area for overlapping sheets.

1.3 Ancillary items used with the membrane include:

- Platon Brick Plug — a plastic plug for fixing the membrane to brick and stone. The plug has a pre-formed hole permitting timber fixings to be inserted without breaching the membrane (see Figure 2)
- Platon Plug Seal — a pre-formed rubber grommet to form a seal when using Platon Brick Plugs
- Platon Sealing Tape — butyl rubber tape for sealing joints in the membrane
- Platon Sealing Rope — butyl rubber beading for sealing joints in the membrane and sealing the membrane around pipes and openings, and to form a gasket between the brick plug and membrane
- Platon Sealer — butyl rubber sealant for sealing the membrane around pipes and openings

- Platon Overtape — butyl rubber tape, at least 100 mm wide, backed with non-woven polypropylene, for sealing joints in the membrane, and for use around services, penetrations and edge details, and between wall and floor membranes
- Platon Corner Strip — 150 mm x 10 m roll. A self-adhesive membrane strip for sealing junctions between walls and floors, and for sealing joints at corners.

Figure 2 Platon Brick Plug fixing detail

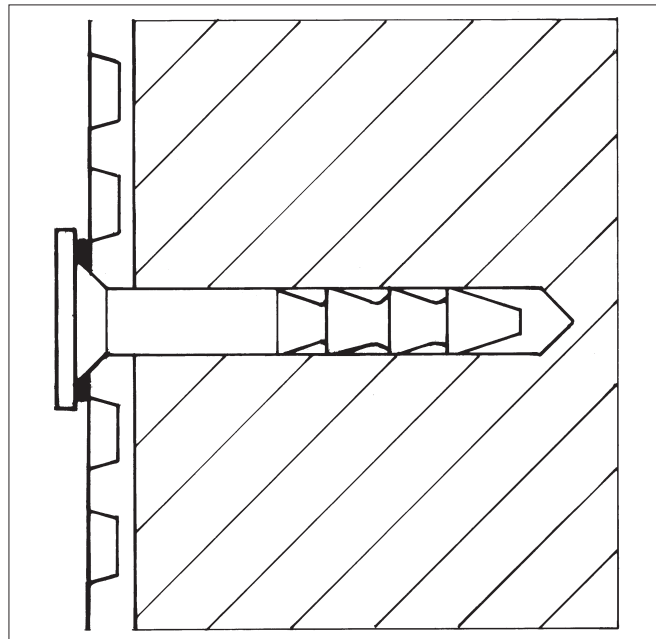

2 Manufacture

2.1 The membrane is formed in a continuous process in which HDPE is extruded into sheets and the stud impressions formed.

2.2 As part of the assessment and ongoing surveillance of product quality, the BBA has:

- agreed with the manufacturer the quality control procedures and product testing to be undertaken
- assessed and agreed the quality control operated over batches of incoming materials
- monitored the production process and verified that it is in accordance with the documented process
- evaluated the process for management of nonconformities
- checked that equipment has been properly tested and calibrated
- undertaken to carry out the above measures on a regular basis through a surveillance process, to verify that the specifications and quality control operated by the manufacturer are being maintained.

2.3 The management systems of Isola AS, Platon Factory have been assessed and registered as meeting the requirements of BS EN ISO 9001 : 2008 by DNV (Certificate QSC – 6011).

2.4 Platon P8 is marketed in the UK by Triton Chemical Manufacturing Co Ltd (t/a Triton Systems Ltd), Units 3-5, Crayford Commercial Centre, Greyhound Way, Crayford, Kent, DA1 4HF, Tel: 01322 318830, Fax: 01322 524017, e-mail: info@tritonchemical.co.uk, website: www.tritonchemical.co.uk

3 Delivery and site handling

3.1 The membrane is delivered to site in wrapped rolls bearing the product and manufacturer's name and the BBA logo incorporating the number of this Certificate.

3.2 Rolls should be stored on end, under cover and protected from sharp objects, sunlight and high temperatures.

Assessment and Technical Investigations

The following is a summary of the assessment and technical investigations carried out on Platon P8.

Design Considerations

4 Use

4.1 Platon P8 is satisfactory for use as a damp-proof membrane on walls, floors and vaulted ceilings, above and below ground, in new construction or in existing buildings over a contaminated or damp background. It can support a dry lining, screed or flooring, in the following situations:

- on damp walls and floors in underground situations subject to high groundwater levels and perennial moisture

- on vaulted ceilings of archways or cellars subject to water ingress
- in conjunction with a remedial damp-proof course (dpc) system, where the walls and floors have a high salt content, and/or it is necessary to complete the installation immediately without allowing a period for initial drying
- over walls and floors which have a friable or painted surface, are contaminated (eg with oil or mould) or have a high salt content
- as a waterproofing membrane in areas subject to vibration.

4.2 Depending on the application required and the site conditions, the membrane may be used as:

- an underfloor damp-proof membrane
- a dry-lining for walls, vented into the room via aeration slots at the top and bottom of the wall
- a sealed system covering floor, wall and ceiling with provision made for disposing of water build-up behind the membrane via a sump and pump.

4.3 The membrane has not been assessed for use in chemically-contaminated areas, such as brownfield sites.

4.4 The system is satisfactory for use in Type C (drained protection) structural concrete constructions in accordance with BS 8102 : 2009.

4.5 Under normal operating conditions, the membrane is not affected by underfloor heating.

5 Practicability of installation

The product is designed to be installed by competent specialist contractors experienced with damp-proofing work.

6 Resistance to water and water vapour

 6.1 The membrane is water resistant and has a high resistance to water vapour transmission. However, the product as installed is not resistant to hydrostatic pressure and, consequently, the measures described in the *Installation* part of this Certificate must be followed to ensure that the membrane acts as a drainage layer with no excessive build-up of water behind it.

6.2 All joints and fixings must be sealed with Platon sealing products, and drainage channels and gullies, or sumps and pumps should be installed as necessary to disperse excess or standing water.

7 Risk of condensation

7.1 As with any room, there is a need to control the generation and dispersal of moisture in the internal environment and to select appropriate and robust designs to minimise the risk of both surface and interstitial condensation, especially where insulation is used over the membrane.

7.2 In common with most waterproofing membranes, the product has a very high resistance to vapour diffusion, and, when placed on the cold side of a construction, may increase the risk of interstitial condensation. A calculation should be carried out to BS 5250 : 2011, and designers should consider appropriate techniques for managing the safe egress of moisture vapour with care (such as control of the internal room environment or use of a vapour control layer on the warm side of the insulation), and in particular the effect of moisture on any materials at, or in contact with materials below, the local dew-point.

8 Resistance to salt transfer

The product provides an effective barrier to the transmission of salts or other contaminants from the substrate.

9 Resistance to puncture, impact and loading

9.1 The membrane has a high resistance to puncture and will not be damaged by normal foot traffic during installation or while laying concrete or screeding to BS 8204-1 : 2003.

9.2 The membrane can support the long-term imposed loadings defined in the UK National Annex to BS EN 1991-1-1 : 2002, Table NA.2, categories A to D, without undue deformation.

10 Wall-mounted fittings

Wall-mounted fittings (apart from lightweight items such as framed pictures) should be fixed where possible into battens, the position and number of support fixings into the loadbearing structure of which are predetermined. Only in exceptional circumstances should fittings be fixed through the membrane and lining board to the loadbearing structure behind, using proprietary fixings. Holes made in the membrane must be filled with a flexible sealant, such as Platon Sealer, Platon Sealing Rope or Platon Sealing Tape.

11 Maintenance

11.1 As the membrane is confined within a wall, ceiling or floor space and has suitable durability (see section 12), maintenance is not required.

11.2 Regular maintenance of all gullies, sumps and pumps must be conducted to ensure that a build-up of water does not occur behind the membrane.

12 Durability



Under normal conditions of use, the product will provide an effective barrier to the transmission of salts, liquid water and water vapour for the life of the structure in which it is incorporated.

13 Reuse and recyclability

The product comprises polyethylene, which can be recycled.

Installation

14 Survey

14.1 Where the area to be treated is below ground, or where conditions are damp, a full survey by a specialist waterproofing surveyor is necessary, to diagnose the cause and to establish if treatment is required.

14.2 If rising damp is found, a remedial treatment is conducted in accordance with the relevant Agrément Certificate, BS 6576 : 2005 and the Property Care Association *Code of Practice for Installation of Remedial Damp-proof Courses in Masonry Walls*.

14.3 Appropriate remedial measures are taken to rectify major causes of damp conditions or water ingress, and to repair structural defects.

15 Surface preparation

15.1 When the product is used in new constructions, the concrete base must be laid in accordance with BS 8204-1 : 2003.

15.2 If a board covering is to be laid directly on the membrane, the concrete base must have a surface regularity with a maximum permissible departure of 5 mm from the underside of a 2 m straight edge, resting in contact with the floor in accordance with BS 8204-1 : 2003.

15.3 Any unsound plaster, render or screed is removed to expose the substrate which is then cleaned with a stiff brush to remove loose material, laitance, salt residue, mould or adhesive. If mould is present the substrate should be treated with a fungicidal wash. The Certificate holder can advise on suitable materials and procedures to be used.

15.4 Uneven substrates should be dubbed out with a cement-sand (1:4) render or screed, to the tolerance described in section 15.2. They should be allowed to set before the membrane is fixed.

16 Procedure

General

16.1 Platon P8 may be used in combination with any of the appropriate Platon membranes which are the subject of other Product Sheets of this Certificate.

16.2 The membrane should always be used with the flanged edge positioned in front of and overlapping the previously installed membrane width. Joints with the flanged edge are sealed using Platon Sealing Tape, while stud-to-stud joints (without the flanged edge) are sealed by overlapping the membrane by a minimum of 200 mm and using Platon Overtape.

16.3 At corners where membranes are not installed continuously from one surface to the next, they should be finished at the corner on each surface and sealed together using Platon Overtape.

16.4 Fixings are made through the membrane into 10 mm holes drilled centrally through the studs. Platon Brick Plugs, to which Platon Sealing Rope has been applied around the rim, are inserted into the holes and tapped flush with the membrane. The Platon Sealing Rope forms a sealing gasket between the plug and membrane.

16.5 On walls and ceilings, preservative-treated timber battens of minimum dimensions 25 by 38 mm are fixed into the plug's fixing hole using suitable screws with a maximum screwing-in depth of 25 mm plus the batten depth. If required, Platon Sealer is injected into the fixing holes to reduce the risk of water penetration. The membrane can also be dry-lined, using free-standing framework, blockwork or similar.

Walls

16.6 Installation of the membrane is commenced at the top of the construction. The membrane may require initial fixing on a ceiling or along the upper edge of a wall, prior to final fixings along batten runs. For joints where the flanged edge is not used, the two membrane sheets are overlapped by a minimum of 200 mm, and for horizontal joints the lower sheet is always positioned in front of the upper sheet.

16.7 Spacings between fixings will depend on the method of dry lining to be applied. When using preservative-treated timber battens the fixings should be kept to a maximum of 600 mm. Proprietary metal fast track systems and independent frame systems will require fewer fixings, but sufficient should be used to ensure that the membrane is reasonably tight to the wall, especially at corners.

16.8 The installation is conducted over windows and the membrane is cut away to expose them. The gaps are then sealed with Platon Sealing Tape or Platon Sealing Rope.

16.9 For doors and some obstructions, the technique covered in section 16.8 cannot be used. Instead, the membrane is installed up to the perimeter and the gap sealed in the same manner.

16.10 Power cables, points and light switches should preferably be remounted in front of the membrane.

16.11 In below-ground installations, the practice of leaving the top of the wall membrane unsealed where there is no requirement for a ceiling membrane to be installed may need to be reconsidered in cases where ingress of gases, odours or vermin is a consideration (such as in proximity to food preparation areas). The advice of the Certificate holder should be sought in these situations.

16.12 In above-ground installations, the build-up of water vapour behind the membrane is controlled by venting into the room. To facilitate this, the membrane is installed with a 10 mm gap at the top and a 20 mm gap at the bottom of the wall. Spacers measuring 3 by 200 mm are fixed at 600 mm centres behind the skirting board and ceiling coving to ensure a ventilation gap (see Figure 3). Alternatively, a proprietary ventilated skirting board or ceiling coving may be used.

Figure 3 Wall detail with dry lining (ventilated system)

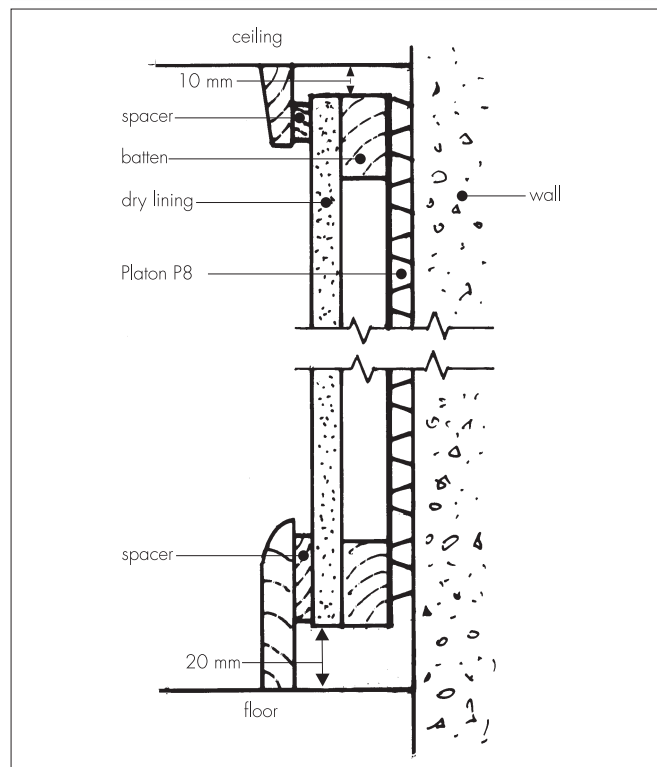

Ceilings

16.13 Ceilings to be covered must always have a fall, as per vaulted cellar constructions, to ensure water does not build up against the membrane or a joint. The vertical drop between the ends of two membrane sheets for horizontal overlaps should be a minimum of 100 mm.

16.14 Any sagging of the membrane between fixing points should not be great enough for ponding to occur.

16.15 At the end walls of vaulted constructions the membrane must be turned down onto the end wall by a minimum 300 mm (ie 12 studs). The membrane is mitred as necessary to fit the curve of the ceiling, and the joint sealed with Platon Sealing Tape or Platon Sealing Rope. The wall membrane should be cut to fit the curve of the ceiling, fixed in front of the ceiling membrane, and the gap sealed with Platon Sealing Tape, Platon Sealing Rope or Platon Sealer.

Floors

16.16 Floors should have a drainage outlet point. There should be a fall towards the outlet point or a drainage channel made around the perimeter of the floor, to ensure that water can flow to the outlet.

16.17 The membrane is rolled out 'studs down' over the floor, and consecutive membrane widths are laid so that the flanged edge overlaps the first sheet by two studs. Joints are sealed using Platon Sealing Tape. Joints without the flanged edge are oversealed using Platon Overtape.

16.18 The membrane is cut within 5 to 10 mm of any pipes and services in the floor, and the gap filled with Platon Sealing Rope. A patch of membrane is overlaid and sealed to the service with Platon Sealing Rope, and its circumference sealed with Platon Sealing Tape.

16.19 Fixings must not be applied through the floor membrane.

16.20 Where appropriate, at wall/floor junctions and corners of the installation, the membrane should be cut flush and the gap between the wall and floor membranes sealed with Platon Overtape. Alternatively, where a wall

membrane is not being installed the floor membrane may be turned up by 100 mm at the wall and cut flush with the top of the finished floor.

17 Dry lining of walls

Gypsum plasterboard to BS EN 520 : 2004, or similar dry lining boards covered by a current Agrément Certificate, are fixed to the battens with galvanized screws or nails, positioned a minimum of 12 mm from the edge of the board. Care should be taken to ensure that penetration of the plasterboard by screws or nails is less than batten depth, to avoid puncturing the membrane.

18 Floor membrane coverings

18.1 If required, extruded, closed-cell polystyrene insulation boards (minimum density 30 kg·m⁻³) are laid over the membrane.

18.2 Suitable tongue-and-groove flooring board panels should be selected in accordance with BS EN 12871 : 2010, and loose-laid over the membrane to within 10 mm of the walls. The panels are staggered and the joints sealed with a thermoplastic wood adhesive to BS EN 204 : 2016.

18.3 Alternatively, the membrane is covered by concrete or screed of minimum thickness 50 mm (or of minimum thickness 65 mm if laid over insulation boards) in accordance with BS 8204-1 : 2003. Care should be taken to ensure the membrane is not displaced when placing the concrete or screed. The concrete screed should be reinforced to inhibit shrinkage cracks.

18.4 Proprietary screeds, which can generally be laid at thicknesses less than 50 mm, may also be considered but use of these products with the membrane has not been assessed by the BBA, and is outside the scope of this Certificate.

19 Finishing works

After the product has been installed and the walls dry-lined, permanent decorations, such as vinyl papers or oil paints, may be applied. Temporary permeable decorations (necessary with traditional, cement-based waterproofers) are not necessary for use with the product.

Technical Investigations

20 Tests

20.1 Tests were carried out on Platon P8 and the results assessed to determine:

- thickness
- resistance to short-term compression
- resistance to long-term loading
- nail-tear resistance
- effectiveness of sealing rope/membrane bond.

20.2 Independent test reports were examined and assessed, relating to:

- melt flow index
- tensile strength and elongation at break.

21 Investigations

21.1 The manufacturing process was evaluated, including the methods adopted for quality control, and details were obtained of the quality and composition of the materials used.

21.2 An assessment was made of the scope of use and durability of the product in relation to the generic properties of the membrane.

Bibliography

BS 5250 : 2011 + A1 : 2016 *Code of practice for control of condensation in buildings*

BS 6576 : 2005 + A1 : 2012 *Code of practice for diagnosis of rising damp in walls of buildings and installation of chemical damp-proof courses*

BS 8102 : 2009 *Code of practice for protection of below ground structures against water from the ground*

BS 8204-1 : 2003 + A1 : 2009 *Screeds, bases and in-situ floorings — Concrete bases and cementitious levelling screeds to receive floorings — Code of practice*

BS EN 204 : 2016 *Classification of thermoplastic wood adhesives for non-structural applications*

BS EN 520 : 2004 + A1 : 2009 *Gypsum plasterboards — Definitions, requirements and test methods*

NA to BS EN 1991-1-1 : 2002 *UK National Annex to Eurocode 1 — Actions on structures — General actions — Densities, self-weight, imposed loads for buildings*

BS EN 12871 : 2013 *Wood-based panels — Determination of performance characteristics for load bearing panels for use in floors, roofs and walls*

BS EN 13967 : 2012 *Flexible sheets for waterproofing — Plastic and rubber damp proof sheets including plastic and rubber basement tanking sheet — Definitions and characteristics*

BS EN 13984 : 2013 *Flexible sheets for waterproofing — Plastic and rubber vapour control layers — Definitions and characteristics*

BS EN ISO 9001 : 2008 *Quality management systems — Requirements*

Property Care Association COP09 *Code of Practice for Installation of Remedial Damp-proof Courses in Masonry Walls*

Conditions of Certification

21 Conditions

21.1 This Certificate:

- relates only to the product/system that is named and described on the front page
- is issued only to the company, firm, organisation or person named on the front page — no other company, firm, organisation or person may hold or claim that this Certificate has been issued to them
- is valid only within the UK
- has to be read, considered and used as a whole document — it may be misleading and will be incomplete to be selective
- is copyright of the BBA
- is subject to English Law.

21.2 Publications, documents, specifications, legislation, regulations, standards and the like referenced in this Certificate are those that were current and/or deemed relevant by the BBA at the date of issue or reissue of this Certificate.

21.3 This Certificate will remain valid for an unlimited period provided that the product/system and its manufacture and/or fabrication, including all related and relevant parts and processes thereof:

- are maintained at or above the levels which have been assessed and found to be satisfactory by the BBA
- continue to be checked as and when deemed appropriate by the BBA under arrangements that it will determine
- are reviewed by the BBA as and when it considers appropriate.

21.4 The BBA has used due skill, care and diligence in preparing this Certificate, but no warranty is provided.

21.5 In issuing this Certificate, the BBA is not responsible and is excluded from any liability to any company, firm, organisation or person, for any matters arising directly or indirectly from:

- the presence or absence of any patent, intellectual property or similar rights subsisting in the product/system or any other product/system
- the right of the Certificate holder to manufacture, supply, install, maintain or market the product/system
- actual installations of the product/system, including their nature, design, methods, performance, workmanship and maintenance
- any works and constructions in which the product/system is installed, including their nature, design, methods, performance, workmanship and maintenance
- any loss or damage, including personal injury, howsoever caused by the product/system, including its manufacture, supply, installation, use, maintenance and removal
- any claims by the manufacturer relating to CE marking.

21.6 Any information relating to the manufacture, supply, installation, use, maintenance and removal of this product/system which is contained or referred to in this Certificate is the minimum required to be met when the product/system is manufactured, supplied, installed, used, maintained and removed. It does not purport in any way to restate the requirements of the Health and Safety at Work etc. Act 1974, or of any other statutory, common law or other duty which may exist at the date of issue or reissue of this Certificate; nor is conformity with such information to be taken as satisfying the requirements of the 1974 Act or of any statutory, common law or other duty of care.