



www.tritonsystems.co.uk

Triton Systems

Units 3-5 Crayford Commercial Centre, Greyound Way, Crayford, Kent, DA1 4HF

Telephone: 01322 318830
Fax: 01322 524017
Email: info@tritonsystems.co.uk
Web: www.tritonsystems.co.uk

THIS DRAWING IS THE PROPERTY OF TRITON SYSTEMS AND MUST NOT BE LOANED OR COPIED WITHOUT PRIOR WRITTEN CONSENT

© 2018 TRITON SYSTEMS

NOTE

ALL INSTALLATION TO BE CARRIED OUT IN STRICT ACCORDANCE WITH MANUFACTURERS INSTALLATION INSTRUCTIONS. FOR FURTHER ASSISTANCE CONTACT TRITON TECHNICAL ON THE TELEPHONE NUMBER ABOVE.

THIS TRITON TYPICAL DETAIL IS INTENDED FOR GUIDANCE ONLY AND IS NOT A DESIGN. THE CONCRETE THICKNESSES AS ILLUSTRATED RELATE TO THE REQUIREMENT FOR TT ADMIX PERFORMANCE AND ARE NOT INTENDED TO IMPLY SUITABILITY FOR ANY SPECIFIC STRUCTURAL REQUIREMENTS FOR A PROJECT.

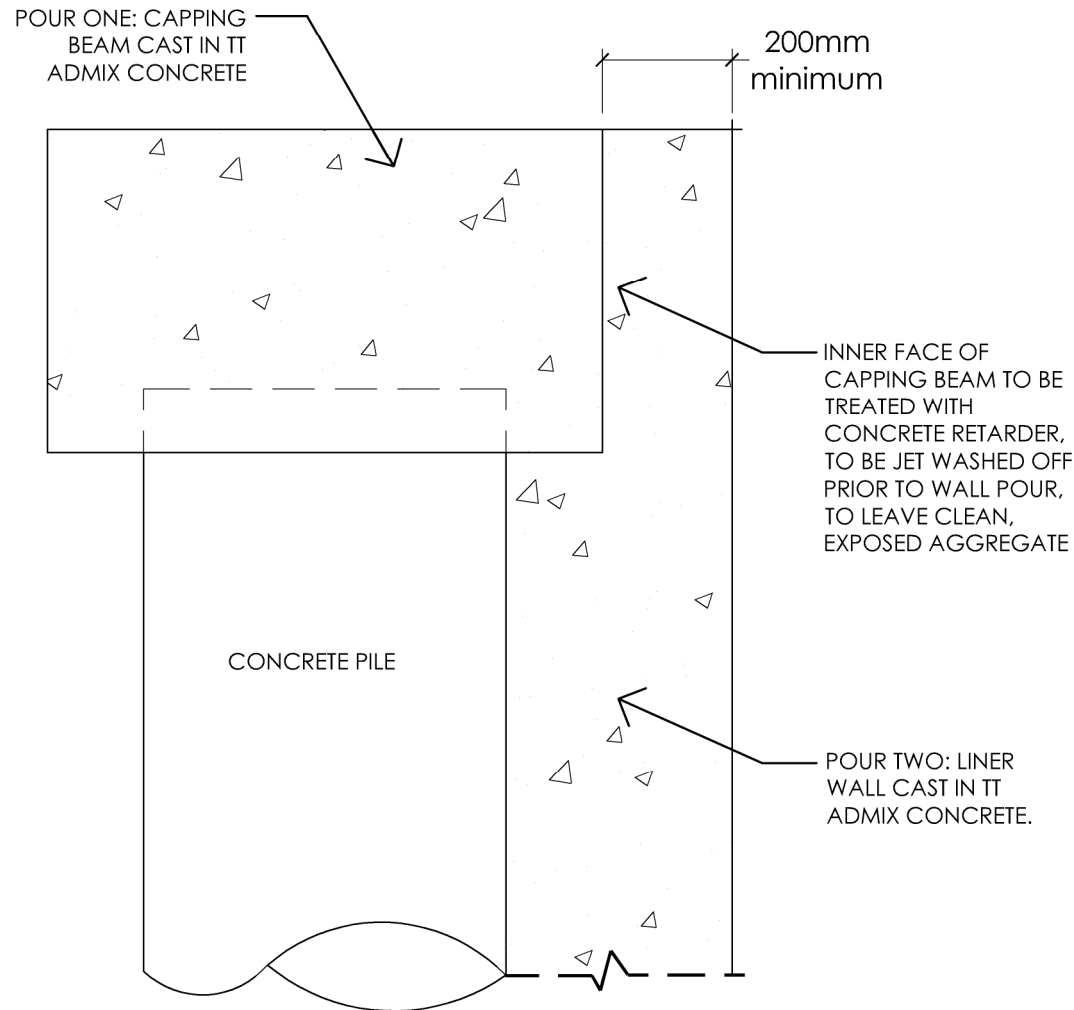

REV	MOD. BY	CHECK. BY	DATE
-----	---------	-----------	------

TITLE

CAPPING BEAM AND LINER WALL (1)

TYPE B INTEGRAL WATERPROOFING TT ADMIX

DRAWN	MB, MD	DRAWING NO:
DATE	APR 2018	TTA - 007
SCALE	N.T.S	